

CM0504FBQ1 TYPE

●FEATURE

1. Capable of handling the highest current of any chip-type common mode filter
2. Noise is greatly suppressed.
3. AEC-Q200 Qualified

●Applications

1. Used for power line noise suppression for any electronic devices. Used to counter adapter/battery line noise for relatively large electronic devices such as notebook , stand-alone word processor, etc.

●Shape and Dimension

●Schematics and Land Patterns(mm)

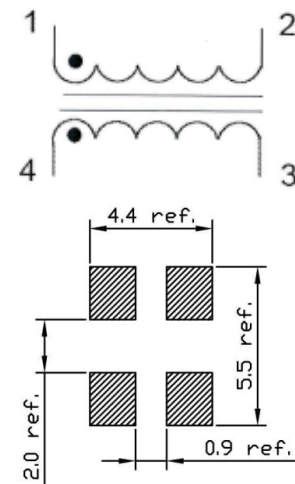
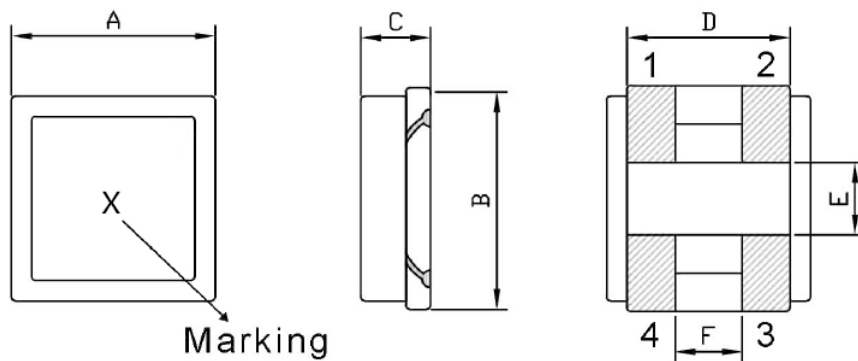

A=4.80±0.30 m/m ; B=5.00±0.30 m/m ; C=4.50 m/m Max ;
 D=3.50 m/m Ref. ; E=2.20 m/m Ref. ; F=1.10 m/m Ref.

●Specification

| Part number | Common mode Impedance Z(Ω) at 100MHz | DC Resistance (mΩ) ±40% | Rated Current(A) | Rated Voltage(V) | Insulation Resistance (MΩ)Min | BLACK MARKING |
|----------------|---|----------------------------|---------------------|---------------------|-------------------------------------|------------------|
| | typical | | | | | |
| CM0504FBQ1-191 | 190 | 10 | 5.0 | 80 | 10 | C |
| CM0504FBQ1-251 | 250 | 14 | 5.0 | 80 | 10 | D |
| CM0504FBQ1-501 | 500 | 15 | 5.0 | 80 | 10 | E |
| CM0504FBQ1-102 | 1000 | 16 | 4.5 | 80 | 10 | F |
| CM0504FBQ1-152 | 1500 | 20 | 4.0 | 80 | 10 | G |
| CM0504FBQ1-202 | 2000 | 35 | 3.5 | 80 | 10 | J |

Note1. Measurement ambient temperature of Impedance, DCR and IDC : at 25°C

Note2. Packing: reel ; Quantity: 1500pcs/reel

GENERAL CHARACTERISTICS

1. Operating temperature range: -40 TO + 125°C (Includes temperature when the coil is heated)
2. High temperature exposure(storage) refer MIL-STD-202 Method 108: 1000 hrs at rated operating temperature(e.g. 125°C). Part can be stored for 1000 hrs @125°C. Unpowered. Measurement at 24±4 hours after test conclusion.
3. Temperature cycling refer JESD22 Method JA-104: 1000 cycles(-40 TO + 125°C). Measurement at 24±4 hours after test conclusion. 30 min maximum dwell time at each temp. extreme. 1 min. maximum transition time.
4. Biased Humidity refer MIL-STD-202 Method 103: 1000 hours 85°C/85%RH. Unpowered. Measurement at 24±4 hours after test conclusion.
5. Operational Life refer MIL-PRF-27: 1000 hrs. at 125 °C tested. Measurement at 24±4 hours after test conclusion.
6. External Visual refer MIL-STD-883 Method 2009: Inspect device construction, marking and workmanship.
7. Physical Dimension refer JESD22 Method JB-100: Verify physical dimensions to the applicable device detail specification.
8. Resistance to Solvents refer MIL-STD-202 Method 215: Add aqueous wash chemical - OKEM clean or equivalent.
9. Mechanical Shock refer MIL-STD-202 Method 213: Figure 1 of Method 213. Condition C.
10. Vibration refer MIL-STD-202 Method 204: 5g;s for 20 minutes, 12 cycles each of 3 orientations. Test from 10-2000 Hz.
11. Resistance to soldering Heat refer MIL-STD-202 Method 210: Condition B No pre-heat of samples. Single wave solder-procedure 2 for SMD and procedure 1 for leaded with solder within 1.5mm of device body.
12. ESD refer AEC-Q200-002 or ISO/DIS 10605: Direct contact discharge 2kV.
13. Solderability refer J-STD-002: For both Leaded & SMD. Magnification 50X. Conditions: Leaded, Method A@235°C, category 3 ; SMD, a)Method B, 4hrs@125°C dry heat @235°C, b)Method B@215°C category 3., c)Method D category 3@260°C
14. Electrical Characterization refer spec: Show Min, Max Mean and Standard deviation at room from Min and Max temperature.
15. Flammability refer UL-94: V-0 or V-1 Acceptable.
16. Board Flex refer AEC-Q200-005: 60 sec minimum holding time.
17. Terminal Strength(SMD) refer AEC-Q200-006