

CM7060FBQ1 TYPE

●FEATURE

- Noise is greatly suppressed.

●Applications

- Automotive inductor, AEC-Q200 Qualified
- Same as Vishay ICM-2824 and TDK ACM7060 series

●Shape and Dimension

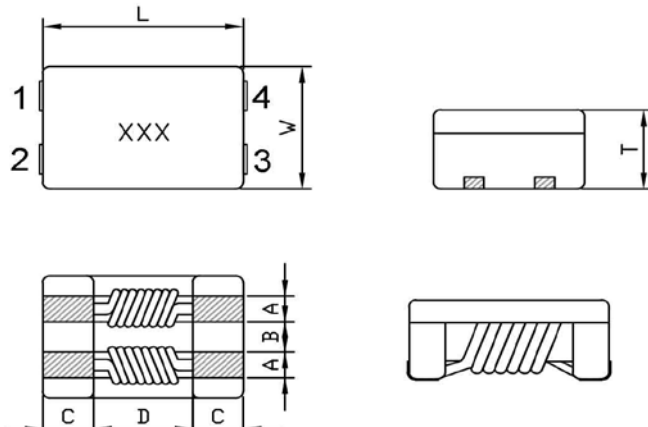

●Schematics and Land Patterns(mm)

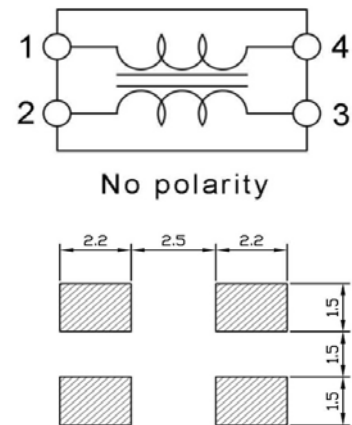

L=7.30±0.30 m/m ; W=6.00±0.20 m/m ; T=3.80 m/m Max ; A=1.50 m/m Ref. ; B=1.50 m/m Ref.
C=1.70 m/m Ref. ; D=3.50 m/m Ref ; Black cover

●Specification

Part number	Common mode Impedance Z(Ω) at 100MHz		DC Resistance (mΩ Max)	Rated Current(A)	Rated Voltage(V)	Insulation Resistance (MΩ)Min
	min	typical				
CM7060FBQ1-400	40	70	5.0	15.0	80	10
CM7060FB-Q1101	100	140	10.0	9.0	80	10
CM7060FBQ1-301	225	300	10.0	5.0	80	10
CM7060FBQ1-501	275	500	10.0	5.0	80	10
CM7060FBQ1-601	500	700	15.0	4.0	80	10
CM7060FBQ1-701	500	700	15.0	4.0	80	10
CM7060FBQ1-102	800	1020	17.0	3.0	80	10
CM7060FBQ1-132	910	1300	21.0	2.5	80	10
CM7060FBQ1-272	2000	2700	63.0	1.0	80	10
CM7060FBQ1-302	2500	3000	75.0	0.9	80	10

Note1. Measurement ambient temperature of Impedance, DCR and IDC : at 25°C

Note2. Packing: reel ; Quantity: 1500pcs/reel

GENERAL CHARACTERISTICS

1. Operating temperature range: -40 TO + 125°C (Includes temperature when the coil is heated)
2. High temperature exposure(storage) refer MIL-STD-202 Method 108: 1000 hrs at rated operating temperature(e.g. 125°C). Part can be stored for 1000 hrs @125°C. Unpowered. Measurement at 24±4 hours after test conclusion.
3. Temperature cycling refer JESD22 Method JA-104: 1000 cycles(-40 TO + 125°C). Measurement at 24±4 hours after test conclusion. 30 min maximum dwell time at each temp. extreme. 1 min. maximum transition time.
4. Biased Humidity refer MIL-STD-202 Method 103: 1000 hours 85°C/85%RH. Unpowered. Measurement at 24±4 hours after test conclusion.
5. Operational Life refer MIL-PRF-27: 1000 hrs. at 125 °C tested. Measurement at 24±4 hours after test conclusion.
6. External Visual refer MIL-STD-883 Method 2009: Inspect device construction, marking and workmanship.
7. Physical Dimension refer JESD22 Method JB-100: Verify physical dimensions to the applicable device detail specification.
8. Resistance to Solvents refer MIL-STD-202 Method 215: Add aqueous wash chemical - OKEM clean or equivalent.
9. Mechanical Shock refer MIL-STD-202 Method 213: Figure 1 of Method 213. Condition C.
10. Vibration refer MIL-STD-202 Method 204: 5g;s for 20 minutes, 12 cycles each of 3 orientations. Test from 10-2000 Hz.
11. Resistance to soldering Heat refer MIL-STD-202 Method 210: Condition B No pre-heat of samples. Single wave solder-procedure 2 for SMD and procedure 1 for leaded with solder within 1.5mm of device body.
12. ESD refer AEC-Q200-002 or ISO/DIS 10605: Direct contact discharge 2kV.
13. Solderability refer J-STD-002: For both Leaded & SMD. Magnification 50X. Conditions: Leaded, Method A@235°C ,category 3 ; SMD, a)Method B, 4hrs@125°C dry heat @235°C, b)Method B@215°C category 3., c)Method D category 3@260°C
14. Electrical Characterization refer spec: Show Min, Max Mean and Standard deviation at room from Min and Max temperature.
15. Flammability refer UL-94: V-0 or V-1 Acceptable.
16. Board Flex refer AEC-Q200-005: 60 sec minimum holding time.
17. Terminal Strength(SMD) refer AEC-Q200-006

● Characteristics

CM7060FBQ1-301

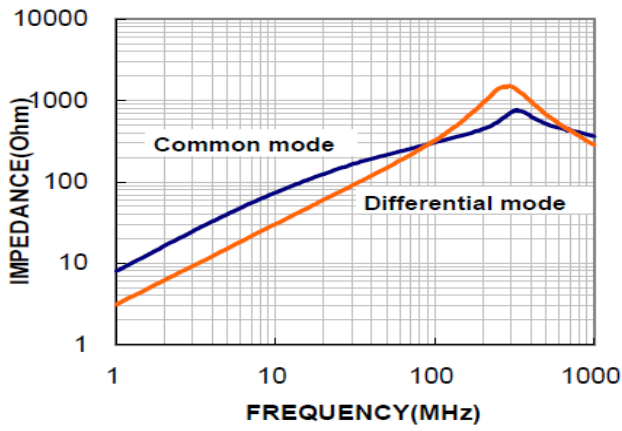

CM7060FBQ1-701

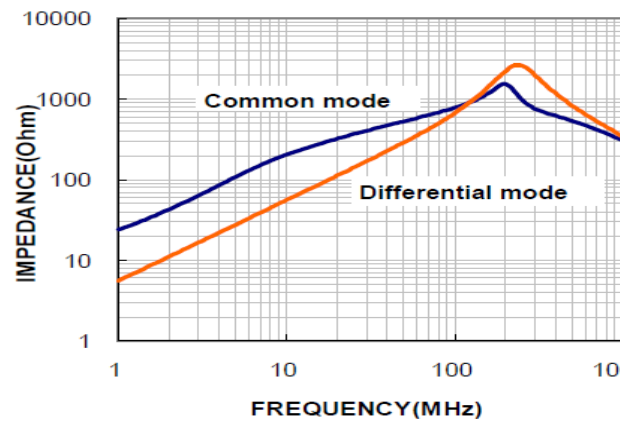

CM7060FBQ1 -102

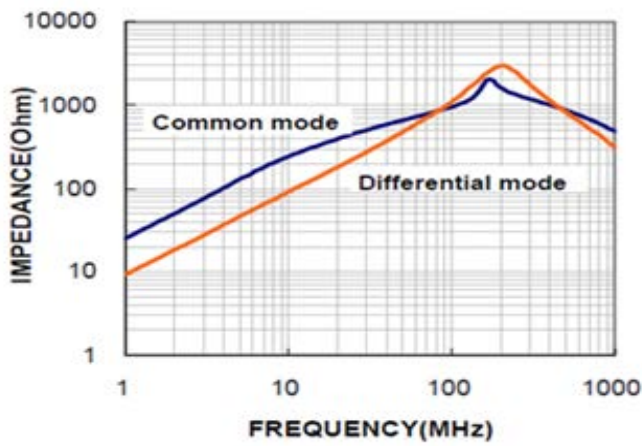

CM7060FBQ1 -132

