

CM0502FB TYPE

●FEATURE

1. Capable of handling the highest current(up to 5A) of any chip-type common mode filter
2. Noise is greatly suppressed.
3. Same as Murata DLW5BT series

●Applications

1. Used for power line noise suppression for any electroic devices. Used to counter adapter/battery line noise for relatively large electronic devices such as notebook , stand-alone word processor, etc.

●Shape and Dimension

●Schematics and Land Patterns(mm)

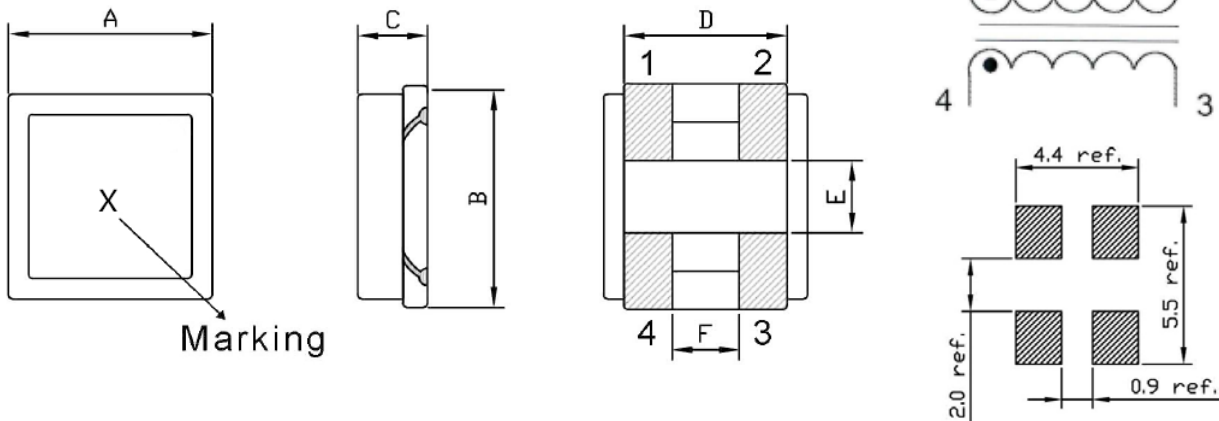

A=4.80±0.30 m/m ; B=5.00±0.30 m/m ; C=2.50 m/m Max (do not include solder); D=3.50 m/m Ref.
E=2.20 m/m Ref. ; F=1.10 m/m Ref.

●Specification

Part number	Common mode Impedance Z(Ω) at 100MHz	DC Resistance (mΩ)±40%	Rated Current(A)	Rated Voltage(V)	Insulation Resistance (MΩ)Min	BLACK MARKING
	typical					
CM0502FB-101	100	9.0	6.0	50	10	A
CM0502FB-251	250	14	5.0	50	10	B
CM0502FB-501	500	19	4.0	50	10	C
CM0502FB-102	1000	24	2.5	50	10	D
CM0502FB-142	1400	40	2.0	50	10	E

Note1. Measurement ambient temperature of Impedance, DCR and IDC : at 25°C

Note2. Packing: reel ; Quantity: 2500pcs/reel

● Characteristics

CM0502FB-101

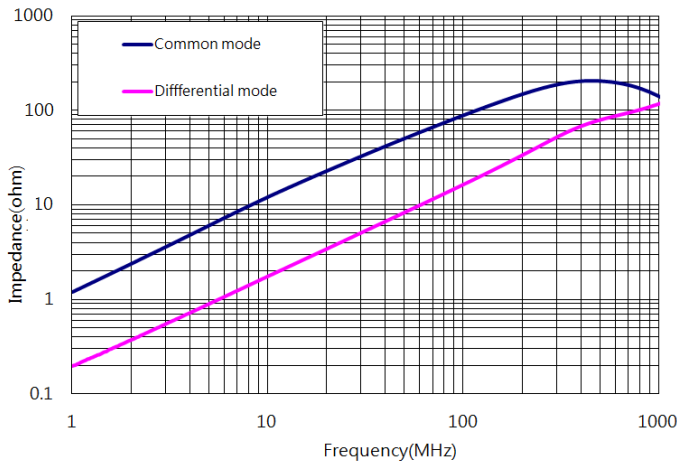

CM0502FB-251

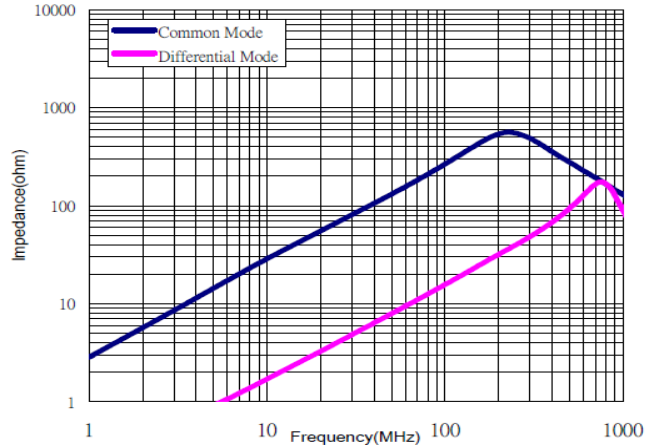

CM0502FB-501

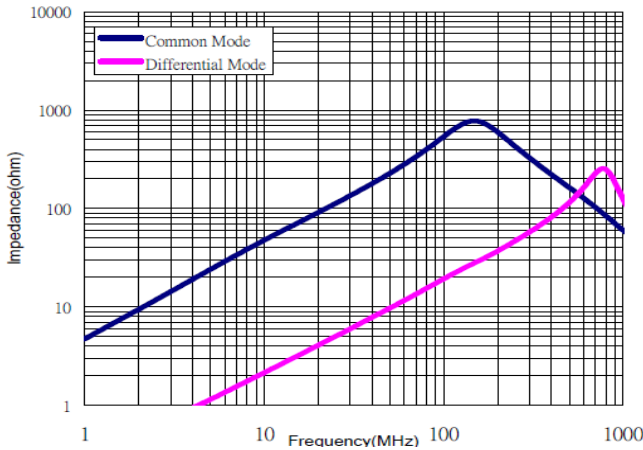

CM0502FB-102

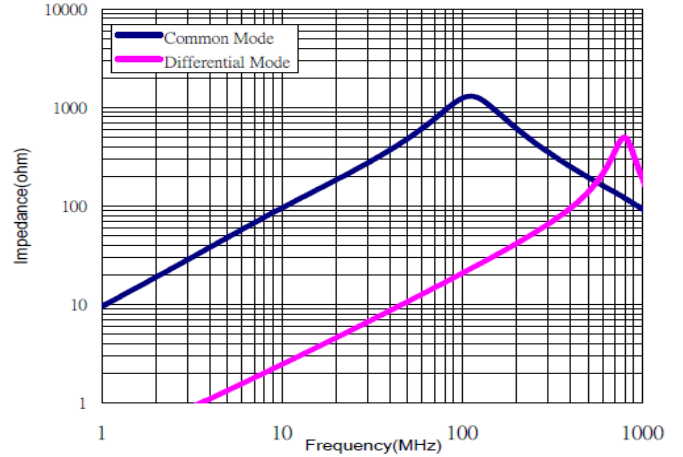

CM0502FB-142

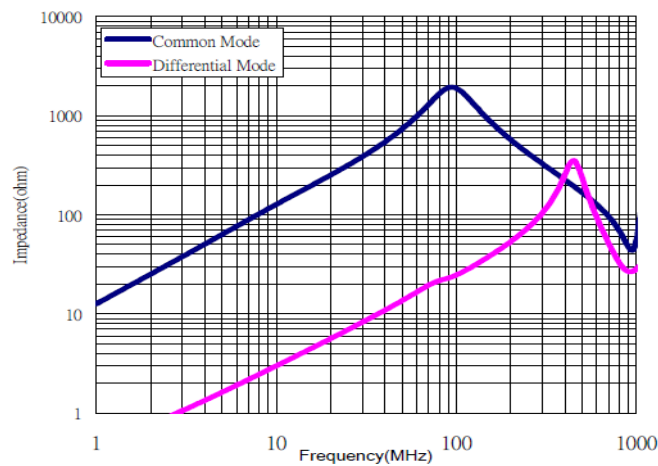

GENERAL CHARACTERISTICS

1. Operating temperature range: -40 TO + 105°C(Includes temperature when the coil is heated)
2. External appearance: On visual inspection, the coil has no external defects.
3. Terminal strength: After soldering. Between copper plate and terminals of coil. Push in two directions of X.Y withstanding at below conditions.

Terminal should not peel off. (refer to figure at right) 5. 0N 60 sec.

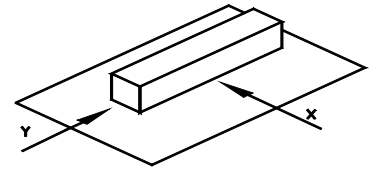

4. Insulating resistance: Over 100MΩ at 100V D.C. between coil and core.
5. Dielectric strength: No dielectric breakdown at 125V D.C. for 1 minute between coil and core.
6. Temperature characteristics: Inductance coefficient $(0\sim2,000)\times 10^{-6}/^{\circ}\text{C}$ (-25~+80°C degree Celsius), inductance deviation within $\pm 5.0\%$, after 96 hours.
7. Humidity characteristics(Moisture Resistance): Inductance deviation within $\pm 5\%$, after 96 hours in 90~95% relative humidity at $40 \pm 2^{\circ}\text{C}$ and 1 hour drying under normal condition.
8. Vibration resistance: Inductance deviation within $\pm 5\%$, after vibration for 1 hour. In each of three orientations at sweep vibration (10~55~10 Hz) with 1.5mm P-P amplitudes.
9. Shock resistance: Inductance deviation within $\pm 5\%$, after being dropped once with 981m/s² (100G) shock attitude upon a rubber block method shock testing machine, in three different orientations.
10. Resistance to Soldering Heat: 260°C, 10 seconds(See attached recommend reflow)
11. Storage condition: Temperature Range: 0°C ~ 35°C ; -40°C ~ 105°C (after PCB) · Humidity Range: 50% ~ 70% RH
12. Use components within 12 months. If 12 months or more have elapsed, check solderability before use.
13. Reflow profile recommend:

Lead-free heat endurance test

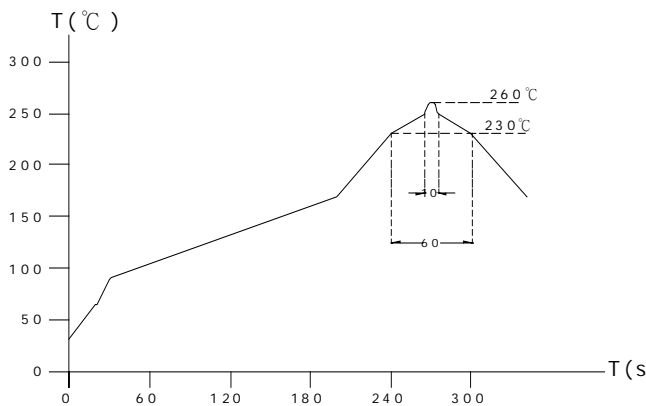

Lead-free the recommended reflow condition

