

SD5D20 TYPE

●FEATURE

1. Low profile and small size(Height=2.00MAX)
2. Low DC resistance
3. Magnetic Shielding type

●Applications

1. Digital camera and others portable

●Shape and Dimension

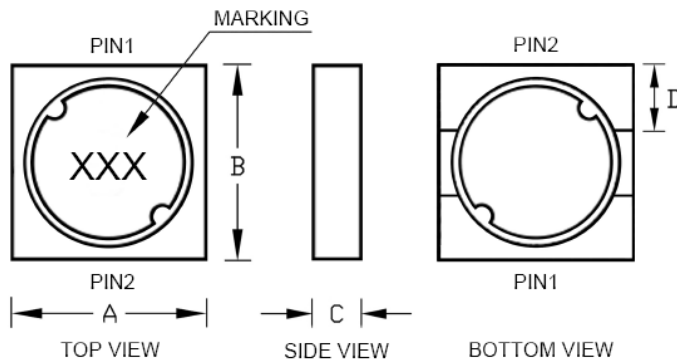

●Schematics and Land Patterns(mm)

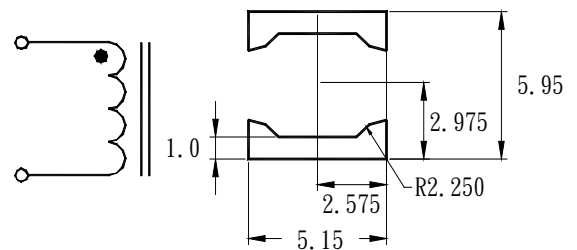

A=5.30m/m MAX ; B=5.30m/m MAX ; C=2.00m/m MAX ; D=1.50m/m TYP. ;

MARKING= Inductance value

●Specification

Part Number	L (uH)	Marking	DCR (ΩTyp.)	Isat (A)	Irms (A)
SD5D20-R47N	0.47±30%	R47	0.0200	4.00	3.59
SD5D20-1R2N	1.2±30%	1R2	0.0275	2.55	3.07
SD5D20-1R5N	1.5±30%	1R5	0.0312	2.15	2.88
SD5D20-2R2N	2.2±30%	2R2	0.0429	1.87	2.45
SD5D20-3R3N	3.3±30%	3R3	0.0547	1.47	2.17
SD5D20-4R7N	4.7±30%	4R7	0.0612	1.33	2.05
SD5D20-6R2N	6.2±30%	6R2	0.0720	1.12	1.89
SD5D20-8R2N	8.2±30%	8R2	0.1000	0.966	1.61
SD5D20-100M	10±20%	100	0.1100	1.000	1.53
SD5D20-150M	15±20%	150	0.1655	0.718	1.25
SD5D20-220M	22±20%	220	0.2053	0.596	1.12
SD5D20-330M	33±20%	330	0.3100	0.491	0.913
SD5D20-470M	47±20%	470	0.4650	0.406	0.745
SD5D20-680M	68±20%	680	0.6947	0.337	0.610
SD5D20-820M	82±20%	820	0.7785	0.308	0.576

Part Number	L (uH)	Marking	DCR (Ω Typ.)	Isat (A)	Irms (A)
SD5D20-101M	100±20%	101	1.06	0.283	0.495
SD5D20-151M	150±20%	151	1.37	0.228	0.435
SD5D20-221M	220±20%	221	2.04	0.188	0.356
SD5D20-331M	330±20%	331	2.99	0.155	0.294
SD5D20-471M	470±20%	471	3.74	0.129	0.263
SD5D20-681M	680±20%	681	5.56	0.107	0.216
SD5D20-821M	820±20%	821	6.22	0.098	0.204
SD5D20-102M	1000±20%	102	8.73	0.088	0.172

Note1. Measurement frequency of Inductance value : at 100KHz

Note2. Measurement ambient temperature of L, DCR and IDC : at 25°C

Note3. Isat: DC current at which the inductance drops 30% from its value without current

Note4. Irms: Average current for 40°C temperature rise from 25°C ambient

Note5. Packaging: Taping ; Quantity: 1000 Pieces/reel

GENERAL CHARACTERISTICS

1. Operating temperature range: -40 TO + 105°C(Includes temperature when the coil is heated)
2. External appearance: On visual inspection, the coil has no external defects.
3. Terminal strength: After soldering. Between copper plate and terminals of coil. Push in two directions of X.Y withstanding at below conditions.
Terminal should not peel off. (refer to figure at right) 5. 0N 60 sec.
4. Insulating resistance: Over 100MΩ at 100V D.C. between coil and core.
5. Dielectric strength: No dielectric breakdown at 100V D.C. for 1 minute between coil and core.
6. Temperature characteristics: Inductance coefficient $(0\sim 2,000)\times 10^{-6}/^{\circ}\text{C}$ (-25~+80°C degree Celsius), inductance deviation within $\pm 5.0\%$, after 96 hours.
7. Humidity characteristics(Moisture Resistance): Inductance deviation within $\pm 5\%$, after 96 hours in 90~95% relative humidity at $40 \pm 2^{\circ}\text{C}$ and 1 hour drying under normal condition.
8. Vibration resistance: Inductance deviation within $\pm 5\%$, after vibration for 1 hour. In each of three orientations at sweep vibration (10~55~10 Hz) with 1.5mm P-P amplitudes.
9. Shock resistance: Inductance deviation within $\pm 5\%$, after being dropped once with 981m/s² (100G) shock attitude upon a rubber block method shock testing machine, in three different orientations.
10. Resistance to Soldering Heat: 260°C, 10 seconds(See attached recommend reflow)
11. Storage condition: Temperature Range: 0°C ~ 35°C ; -40°C ~ 105°C (after PCB) , Humidity Range: 50% ~ 70% RH
12. Use components within 12 months. If 12 months or more have elapsed, check solderability before use.
13. Reflow profile recommend:

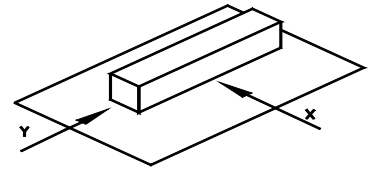

Lead-free heat endurance test

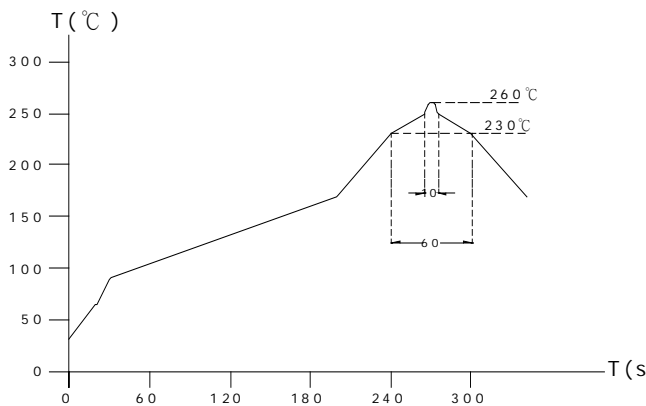

Lead-free the recommended reflow condition

