

## BW1480 TYPE

### ●FEATURE

1. Shielded construction
2. High current and low DCR for flat wire type
3. Cross out as Sumida CDEP147NP-xxxx-95/125 series

### ●Applications

1. Notebook, server application, High current power supplier

### ●Shape and Dimension

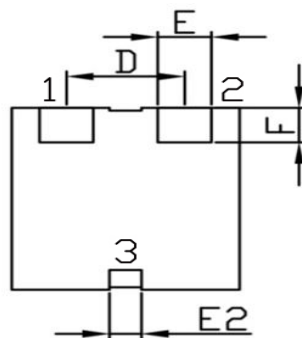
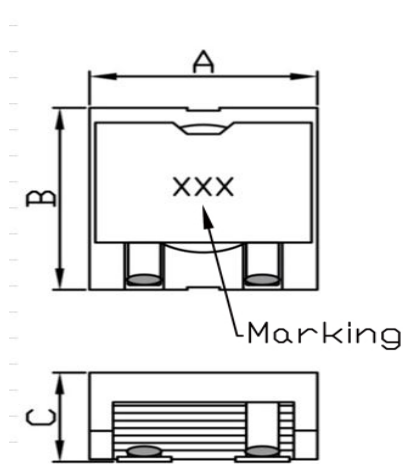

### ●Schematics and Land Patterns(mm)

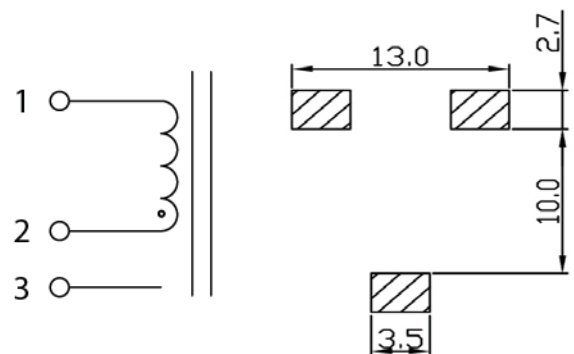

A=14.90m/m Max ; B=15.10m/m Max ; C=8.10m/m MAX; D=9.00±0.50m/m; E=2.80±0.50m/m  
 F=1.80±0.50m/m ; E2=2.50±0.50m/m

### ●Specification

P/N	L ( $\mu$ H)	RDC (m $\Omega$ ) Typical	RDC (m $\Omega$ ) Max	Isat (A)	Irms (A)
BW1480-R40N	0.4±30%	1.0	1.2	66.0	23.0
BW1480-R90M	0.9±20%	1.2	1.5	45.0	21.5
BW1480-1R5M	1.5±20%	1.7	2.0	34.0	20.0
BW1480-2R4M	2.4±20%	2.7	3.2	28.0	17.5
BW1480-3R4M	3.4±20%	4.1	5.0	23.0	16.0
BW1480-4R7M	4.7±20%	5.0	6.0	19.0	12.5
BW1480-6R1M	6.1±20%	6.5	7.8	18.5	11.0
BW1480-7R7M	7.7±20%	8.2	9.9	15.5	10.0
BW1480-9R5M	9.5±20%	11.1	13.3	14.0	8.5
BW1480-100M-LD	10±20%	8.2	9.9	11.5	10
BW1480-120M-LD	12±20%	11.1	13.3	10.0	8.5
BW1480-470M-LD	47±20%	22.3	27.0	3.0	2.5

Note1. Measurement frequency of Inductance value : at 100KHz

Note2. Measurement ambient temperature of L, DCR and IDC : at 25°C

Note3. Isat: DC current at which the inductance drops 25%(typ) from its value without current

Note4. Irms: Average current for 40°C temperature rise from 25°C ambient(typical)

Note5. Inductance tolerance: M:  $\pm 20\%$  ; N:  $\pm 30\%$

Note6. Packaging: Taping ; Quantity: 300 pieces/reel

## GENERAL CHARACTERISTICS

1. Operating temperature range: -40 TO + 125°C (Includes temperature when the coil is heated)
2. External appearance: On visual inspection, the coil has no external defects.
3. Terminal strength: After soldering. Between copper plate and terminals of coil. Push in two directions of X.Y withstanding at below conditions.  
Terminal should not peel off. (refer to figure at right) 5. 0N 60 sec.
4. Insulating resistance: Over 100MΩ at 100V D.C. between coil and core.
5. Dielectric strength: No dielectric breakdown at 100V D.C. for 1 minute between coil and core.
6. Temperature characteristics: Inductance coefficient  $(0\sim 2,000)\times 10^{-6}/^{\circ}\text{C}$  (-25~+80°C).
7. Humidity characteristics(Moisture Resistance): Inductance deviation within  $\pm 5\%$ , after 96 hours in 90~95% relative humidity at  $40 \pm 2^{\circ}\text{C}$  and 1 hour drying under normal condition.
8. Vibration resistance: Inductance deviation within  $\pm 5\%$ , after vibration for 1 hour. In each of three orientations at sweep vibration (10~55~10 Hz) with 1.5mm P-P amplitudes.
9. Shock resistance: Inductance deviation within  $\pm 5\%$ , after being dropped once with 981m/s<sup>2</sup> (100G) shock attitude upon a rubber block method shock testing machine, in three different orientations.
10. Resistance to Soldering Heat: 260°C, 10 seconds(See attached recommend reflow)
11. Storage environment: Storage condition: Temperature Range: 10°C ~ 35°C (Generally: 21°C ~ 31°C) , Humidity Range: 50% ~ 80% RH (Generally: 65% ~ 75%) ; Transportation condition: Temperature Range: -35°C ~ 85°C , Humidity Range: 50% ~ 95% RH
12. Use components within 6 months. If 6 months or more have elapsed, check solderability before use.
13. Reflow profile recommend:

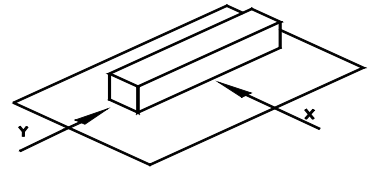

Lead-free heat endurance test

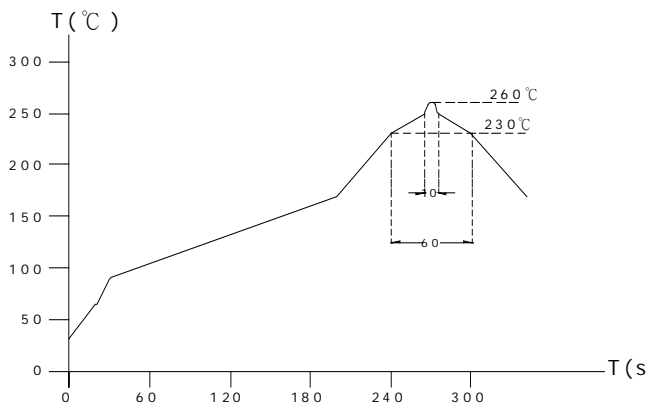

Lead-free the recommended reflow condition

